



PROOFER / HOT CABINET

Wall-Mount / Countertop Insulated

Models: PHC23-AR10 PHC23-AR12

Design Features

- "Cast-in" humidity system prevents element burnout from water spills and potential injury from accidental contact with exposed heating element
- Dual fans uniformly distribute temperature and humidity throughout cabinet
- Separate controls for heat and humidity
- Proof or hold with adjustable temperature from 80°F(27°C) to 180°F (82°C)
- Self-draining feature collects excess moisture into a standard 18" x 26" bun pan (not included) below the base of the cabinet



Quality Construction

Solid Construction for Reliability

- Aluminum construction
- 1 1/2" thick fiberglass insulation throughout top, sides, back and base
- Extruded pan supports accept 18" x 26" pans (side loading)
- Sliding Lexan® doors – easily removable for cleaning
- Completely removable interior components for quick and easy cleaning
- Full-length wall mounting bracket for secure attachment

Options & Accessories

- 4" or 6" stainless steel legs with adjustable feet
- 4" or 5" casters (for under-counter placement)
- Chrome electro-plated wire racks (18"x26")
- 240V electrical system

Warranty & Certifications

Parts and Service Warranty

- Protected by BevLes 2 year parts and 1 year service warranty

Certified by the following:



Mailing: 729 Third Ave., Dallas, TX 75226 • Shipping: 1938 Wyott Dr., Cheyenne, WY 82007
(800) 441-1601 • Fax: (214) 565-0976 • www.bevles.com • sales@bevles.com



PROOFER / HOT CABINET

Wall-Mount / Countertop Insulated

Models: PHC23-AR10 PHC23-AR12

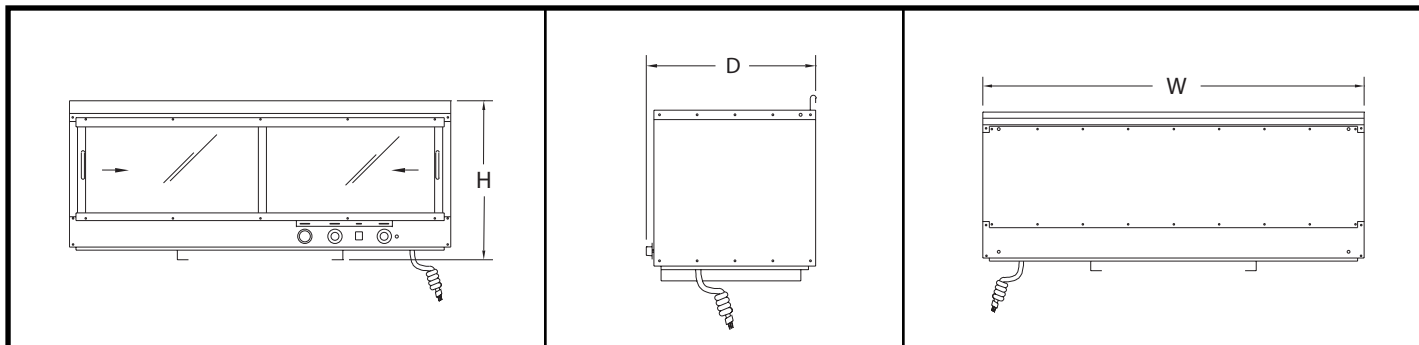

Model	Capacity			Dimensions			Ship Wt.	Act. Wt.
	18x26	12x20	SPC'G	H	W	D		
PHC23-AR10	10	---	3"	24" (61 cm)	60" (152.4 cm)	21" (53.3 cm)	240 lbs (609.6 kg)	225 lbs (102.1 kg)
PHC23-AR12	12	---	2½"	24" (61 cm)	60" (152.4 cm)	21" (53.3 cm)	245 lbs (622.3 kg)	230 lbs (104.3 kg)

Electrical	Voltage	Watts	Amps	Electric Service	Phase	Hertz	Clearances
Standard	120	1400	13	15A Dedicated Circuit	1	50/60	Zero Clearance Cabinet
Optional	240	1400	5.8	15A Dedicated Circuit	1	50/60	Zero Clearance Cabinet

Construction:

- Body: .063 aluminum
- Doors: Clear Lexan with stainless steel edges (sliding type)
- Insulation: Fully insulated back, sides, top and base with 1.5" fiberglass insulation (5.7 R-Factor and minimum rating of .26K per inch)
- Door Gasket: Closed cell foam
- Base: .125 aluminum

Pan Support Assembly:

- Side and Center (Air Duct) Panels: .063 aluminum
- Pan Supports: Extruded aluminum angles on 3" or 2 1/2" centers (bottom supported)
- Extruded pan support/air duct assembly: Aluminum components easily removable for cleaning

Heating Module and Controls:

- Bottom heating unit with two (2) air circulation fans
- Two (2) air heating elements, 500W each, 120V
- Humidity heating element rated at 400W, 120V
- 5 quart (4.7 liter) cast water reservoir
- Easy to operate controls feature precision thermostat, adjustable humidity and dial thermometer

Electrical:

- Switch: 15 Amp, lighted
- Cord and Plug: 120V comes with 8' cord with 15A molded plug (NEMA 5-15P); 24V comes with cord only

Shipping:

- Freight Class: 85
- FOB: Cheyenne, WY 82007

* Note: Modifications involving casters or legs may affect height of equipment. Specifications subject to change without notice.



Mailing: 729 Third Ave., Dallas, TX 75226 • Shipping: 1938 Wyatt Dr., Cheyenne, WY 82007
 (800) 441-1601 • Fax: (214) 565-0976 • www.bevles.com • sales@bevles.com

4/20/05
 #B205